

# FRIALEN®-Spigot Saddles with integral drill SAB

## PE 100 SDR 11

Maximum working pressure 16 bar (Water) / 10 bar (Gas)

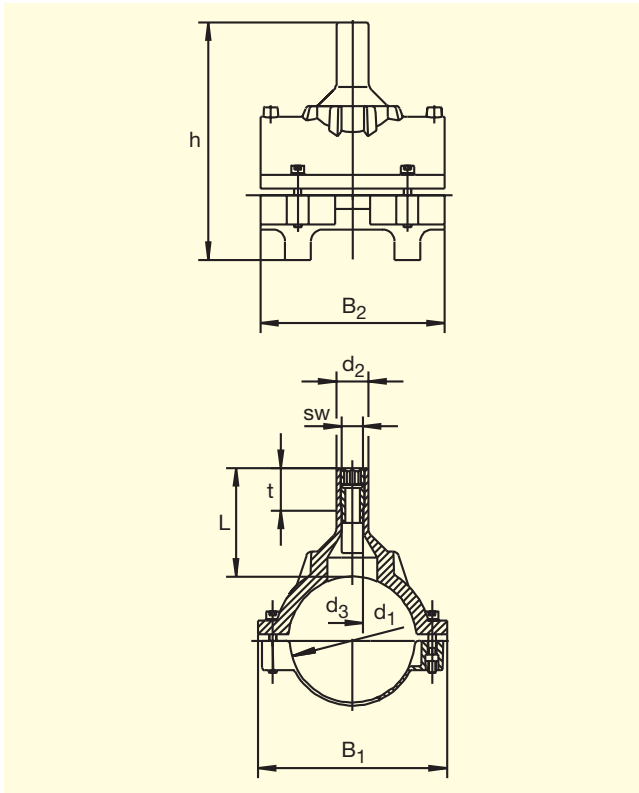

d <sub>1</sub>	d <sub>2</sub>	Order Ref.	Stock-status	VE	PE	d <sub>3</sub>	L	h	t	B <sub>1</sub>	B <sub>2</sub>	SW	Weight kg/each
63	32	T-615 091	1	20	360	21	78	149	43	106	104	17	0.387
90	32	T-615 092	1	20	160	21	89	193	43	155	150	17	0.775
110	32	T-615 093	1	12	96	21	109	233	43	175	180	17	0.972
125	32	T-615 094	1	12	96	21	109	248	43	190	185	17	1.070
160	32	T-615 095	1	6	48	21	109	283	43	225	195	17	1.265

FRIALEN®-Safety Fittings can be fused and tapped to pipes of SDR stages 11 to 17.6  
DVGW-Registration-No.: DV-8606AU2249

Please turn over for important information regarding application of the  
**FRIALEN®**-Spigot Saddles with integral drill SAB

# **FRIALEN<sup>®</sup>-Spigot Saddles with integral drill SAB**

## **PE 100 SDR 11**

Maximum working pressure 16 bar (Water) / 10 bar (Gas)

### **Areas of Application**

The FRIALEN<sup>®</sup>-Spigot Saddles with integral drill SAB are used for tapping in the depressurised state of gas and water pipes. Outlet spigot for use with FRIALEN<sup>®</sup>-couplers MB or UB.

### **Assembly Instructions**

The fusion of the HDPE distribution pipes and the house connections with FRIALEN<sup>®</sup>-Spigot Saddles SAB takes place by FRIALEN<sup>®</sup>-fusing – leakproof and longitudinally strong.

The saddle and the outlet spigot have to be prepared according to the general installation instructions (see “Assembly Instructions” for “FRIALEN<sup>®</sup>-Safety Fittings for house connections and distribution pipes up to d 225”). This involves removing the oxide skin and cleaning the pipe covered by the saddle.

### **Seven good reasons for using the FRIALEN<sup>®</sup>-SAB**

- **Compact construction**
- **HDPE saddle with exposed heating element for optimal heat transfer**
- **Tapping area free of heating wires**
- **Swarfless tapping with integral drill**
- **Preassembled unit without loose parts**
- **Extra wide fusion zone**
- **Additional barcode for tracing back the underground fitting (Traceability-Coding).**

Please find our datasheets for downloading on the internet at [www.friatec.de](http://www.friatec.de)

**For further information, please call our FRIALEN<sup>®</sup>-customer service staff and specialist advisers.**